



Installation instructions

Audi A6 Avant (4G) 2012 ►

**Roof bars for roof rail,
for scope of delivery 4G9.071.151
Audi Genuine Accessories®**

Edition 05.2011



Contents

1	General notes	1
2	Safety notes	2
3	Parts	5
3.1	Scope of delivery	5
3.2	Parts overview	5
4	Installing and removing the roof bars for roof rail	7
4.1	Installing the roof bars for roof rail	7
4.2	Installing add-on components	9
4.3	Removing the roof bars for roof rail	10
4.4	General notes	11
4.5	Adjusting the width of the roof bars for roof rail	11



1 General notes

Please read these instructions carefully and note the WARNING, Caution and Note descriptions before installing the roof bars.

 **WARNING**

Text with this symbol contains information concerning your safety and indicates potential accident and injury risks.

 **Caution**

Text with this symbol indicates the risk of damage to your vehicle.

 **Note**

Text with this symbol contains additional information.

Audi AG shall not accept responsibility in the event of failure to comply with these assembly instructions.



2 Safety notes

Permissible roof load

⚠ WARNING

Do not exceed the permissible roof load of 100 kg (220 lbs.).

Ensure that you do not exceed the maximum permissible gross vehicle weight rating of 100 kg (220 lbs.) for the roof bars for roof rail, add-on components and load.

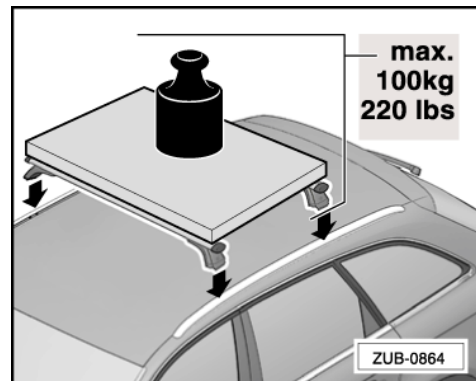

Sensitivity to side winds

⚠ WARNING

The driving and braking behaviour and the vehicle's sensitivity to side winds are changed due to roof load. Adapt your driving style accordingly — risk of accident!

It is recommended that you do not exceed 130 km/h (81 mph).

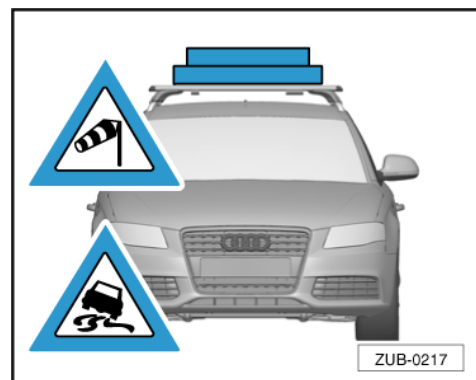

Load — load correctly for the load in question

⚠ WARNING

Load the roof bars for roof rail in the correct manner for the load in question — risk of accident!

Avoid loading on one side — risk of accident!

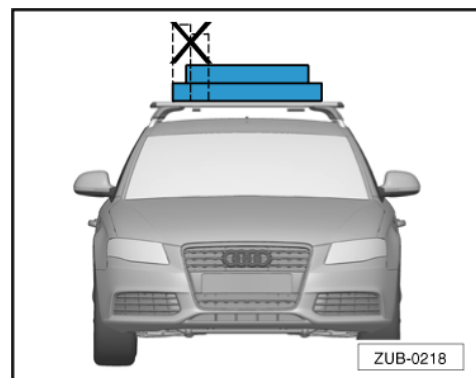

Load — width

⚠ WARNING

Do not exceed the maximum width of the roof bars for roof rail — risk of accident!

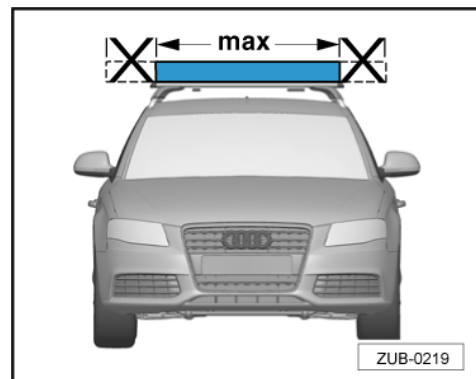



Load — do not tension the roof bars for roof rail against each other

⚠ WARNING

Do not tension the roof bars for roof rail against each other — risk of accident!

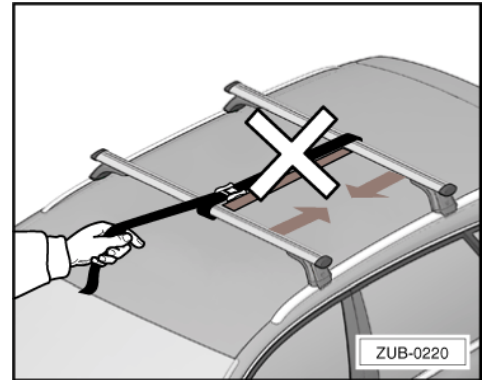

Load — install the roof bars for roof rail first, then install the add-on components

⚠ WARNING

Only fit the add-on components once the roof bars for roof rail have been installed on the vehicle — risk of accident!

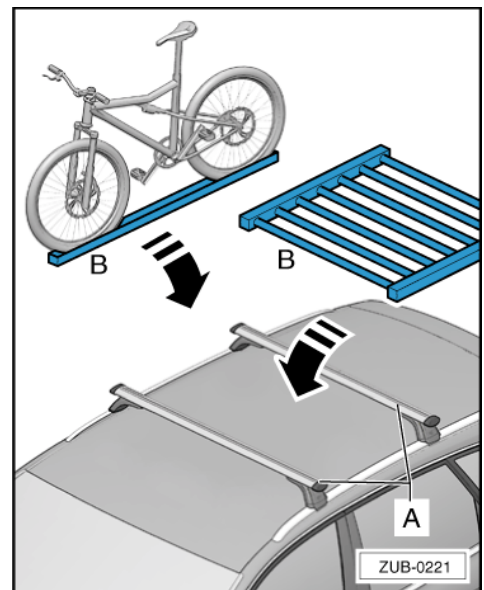

Load — room to open boot lid

⚠ Caution

To prevent damage to the vehicle, make sure that you open the boot lid carefully when installing add-on components (such as a roof box, bicycle rack etc.) and when transporting long items. It is recommended that you adjust the opening angle, if necessary (see Vehicle operating instructions for this) for vehicles with automatic boot lids.

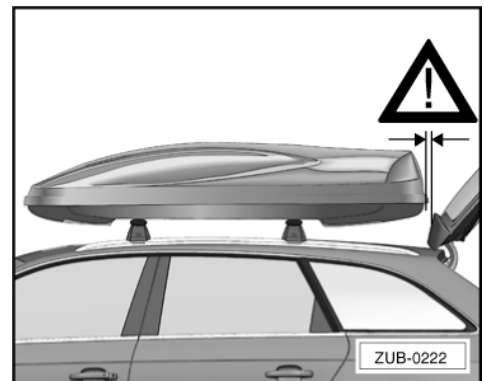

Load — room to open sliding/tilting sunroof

⚠ Caution

Add-on components (such as a roof box, bicycle rack etc.) must be securely fastened in the T groove on vehicles with a sliding/tilting sunroof ⇒ Page 9.

When installing add-on components, check that there is enough room above the sliding/tilting sunroof before opening it. If the add-on components are secured using assembly brackets, the sliding/tilting sunroof must not be opened — risk of damage resulting from a collision!

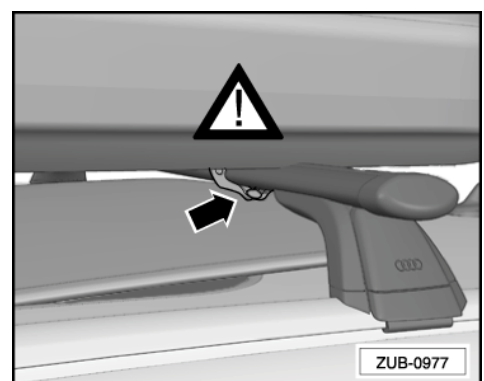



General safety notes

WARNING

Please read these assembly instructions carefully before starting installation. Non-compliance with these assembly instructions and safety notes will compromise your safety and that of third parties.

WARNING

All bolt connections and connections for the roof bars for roof rail and for the add-on components must be checked prior to travelling to ensure they are positioned and installed correctly. Tighten if necessary.

Recheck bolted connections and connections at appropriate intervals and tighten if necessary. The bolted connections and connections must be checked at short intervals if travelling on a poor stretch of road.

If this guideline is not observed, this can result in the roof bars for roof rail or the add-on components becoming loose or falling off — risk of accident!

WARNING

For the safety of other road-users, the roof bars for roof rail and any add-on components must be removed from the vehicle when they are not being used.

WARNING

Repairs or the replacement of parts must only be performed by a qualified workshop. It is recommended that genuine spare parts available from your Audi partner are used.

Caution

The height of the vehicle will change due to the installation of the roof bars for roof rail with/without add-on components. Please pay attention to this when entering garages, driving through tunnels, underpasses etc.

Caution

Do not enter a car wash with the roof bars for roof rail with/without add-on components installed.



3 Parts

3.1 Scope of delivery

- Before installing the roof bars for the roof rail, check parts for completeness.

Units	Description	Information
1	Roof bars for roof rail, front	Label on the underside in direction of travel left
1	Roof bars for roof rail, rear	Label on the underside in direction of travel left
1	Profile cover	Length 2500 mm
1	Torque wrench (6 Nm)	The coding can be found in the safety pass on the reverse side of the document
1	Installation instructions	

UK/US

3.2 Parts overview

- 1 - Profile cover (2x)
- 2 - Profile tube (2x)
- 3 - Upper support bracket (4x)
- 4 - Support plate (4x)
- 5 - Pin link (4x)
- 6 - Rubber support (4x)
- 7 - Lower support bracket (4x)
- 8 - Screws 2.5 x 11 (8x)
- 9 - Compression spring (4x)
- 10 - Claw fastener (4x)
- 11 - Torque wrench (6 Nm)
 - If the torque wrench is misplaced, you can reorder this item from your Audi partner or qualified workshop using the „safety pass“ on the reverse side of the document.
- 12 - Cover flap (4x)
- 13 - Coded tensioning bolt (4x)
- 14 - Washer M6 (4x)
- 15 - Sliding block (4x)
- 16 - Washer M6 (4x)

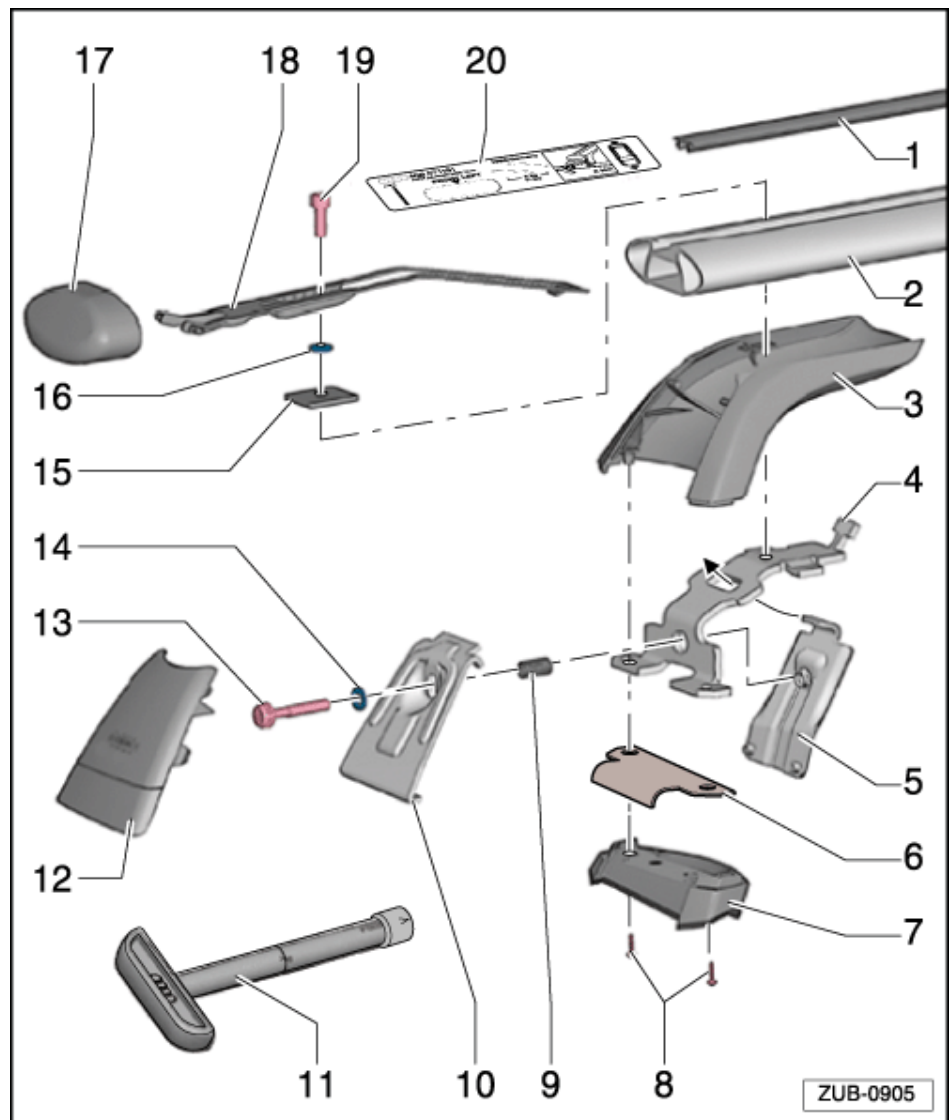



17 - Profile cap (4x)

18 - Profile cap rebound strap (4x)

19 - Hexagon bolt M6 x 12 (4x)

20 - Label (2x)



Note

The labels „front left“ and „rear left“ can each be found on the underside of the profile tubes.



4 Installing and removing the roof bars for roof rail

4.1 Installing the roof bars for roof rail

Note

The roof bars for roof rail must be installed by two people.

There are two holes -X- on the inward facing side of the roof rail at the front and rear end; these holes are provided for installing the roof bars for roof rail.

- Before the installation process can begin, the area around the holes -X- on the roof rail and the rubber supports for the lower support bracket -7- must be free of dust and grease.
- If necessary, clean the contact areas and rubber supports thoroughly.

- Fold up the cover flap -12-.
- Attach the torque wrench -11- on the tensioning bolt -13- so that the markings are aligned.
- Loosen the tensioning bolt -13- far enough for a certain amount of resistance to be detected.

Note

When installing the roof bars for roof rail, make sure that the labels are visible on the left-hand side of the vehicle and that the printed arrow is pointing in the direction of travel.

- Using the label on the underside of the left-hand profile tube as reference, align the roof bars for roof rail to the relevant installation position (left/right and front/rear).
- Place the front and rear roof bars for roof rail in the direction of travel on the area with the holes -X- on the roof rail.

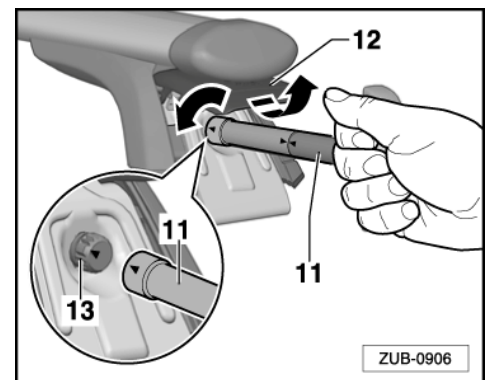
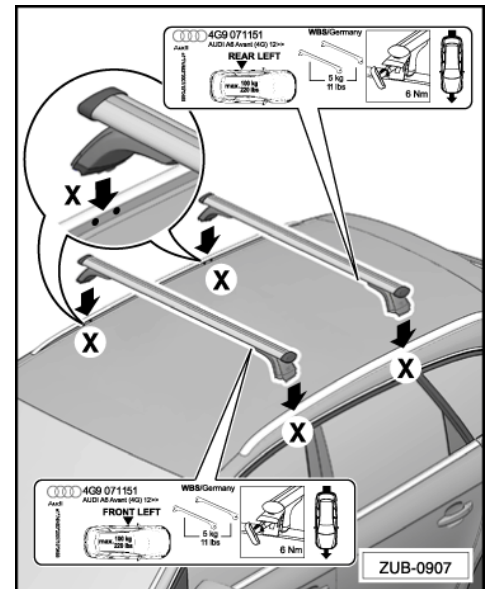



- Insert the two pins in the pin links -5- into the holes -X- in the roof rail. Hold the pin link -5- in this position with your hand.

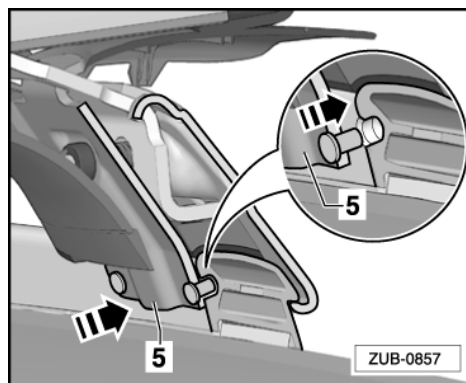

- Hook the claw fastener -10- under the roof rail -arrow-.
- Gently tighten the tensioning bolt -13- using the torque wrench -11-. While doing this, make sure that the claw fastener -10- remains hooked under the roof rail -arrow-.
- Perform the identical procedure on the other side of the vehicle.

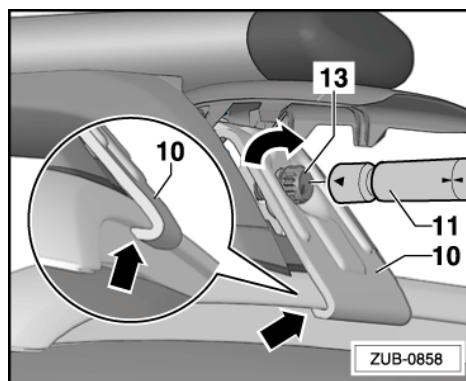

⚠ WARNING

- **The rubber supports for the lower support bracket -7- must sit flush against the roof rail on both sides of the vehicle — risk of accident caused by the roof bars for roof rail coming loose.**

The roof bars for roof rail are in the correct position if:

- ◆ The rubber supports for the lower support bracket -7- sit flush against the roof rail -arrows-
- ◆ The pins in the pin links -5- engage in the holes -X- in the roof rail
- ◆ The claw fastener -10- is hooked under the roof rail

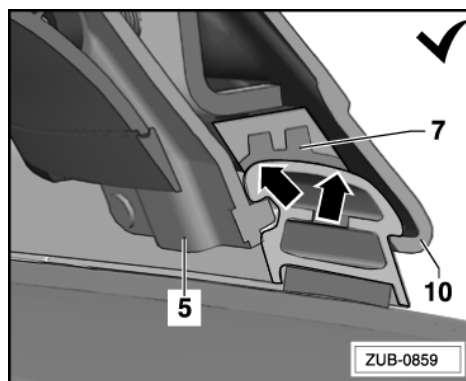

The roof bars for roof rail are positioned too far out if:

- ◆ The rubber supports for the lower support bracket -7- do not sit flush against the roof rail -arrow-
- ◆ The pins in the pin links -5- do not correctly engage in the holes -X- in the roof rail
- ◆ The claw fastener -10- does not hook under the roof rail

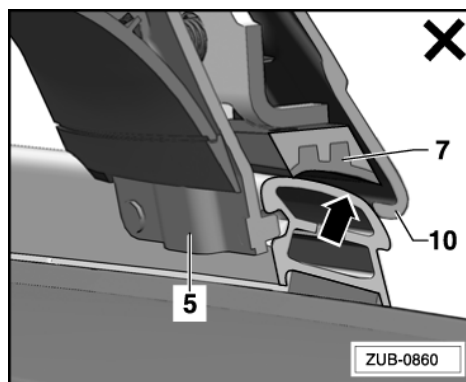



The roof bars for roof rail are positioned too far in if:

- ◆ The rubber supports for the lower support bracket -7- do not sit flush against the roof rail -arrow-
- ◆ The pins in the pin links -5- do not engage in the holes -X- in the roof rail
- ◆ The claw fastener -10- does not hook under the roof rail

If the rubber supports for the lower support bracket -7- do not sit flush against the surface, we recommend that you have the width adjustment checked, and corrected if necessary, by a qualified workshop ⇒ [Page 11](#). Remove the roof bars for roof rail before this process.

Note

- ◆ *When tightening the tensioning bolts -13-, the required tightening torque (or the required tightening force) of 6 Nm is reached once the two arrows on the torque wrench -11- are exactly opposite each other.*
- Tighten the tensioning bolts -13- on both sides alternately to 6 Nm in two steps using the torque wrench -11-.

Caution

The claw fastener -10- must not unhook from the roof rail during this process.

- Check that everything is in the correct position again by tightening the tensioning bolts -13- on both sides to 6 Nm using the torque wrench -11-.
- Close the cover flap -12-.
- Follow the same process to install the second roof bar.

WARNING

All bolt connections and connections for the roof bars for roof rail and for the add-on components must be checked as often as possible and tightened where necessary ⇒ [Page 4](#).

If this guideline is not observed, this can result in the roof bars for roof rail or the add-on components becoming loose or falling off — risk of accident!

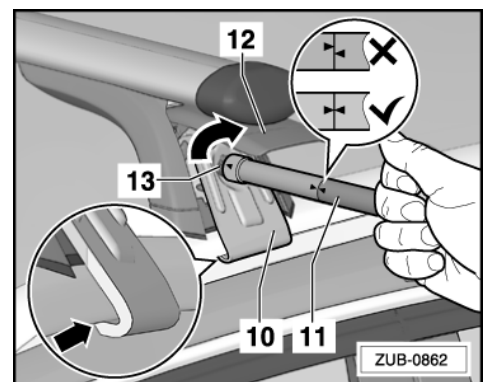
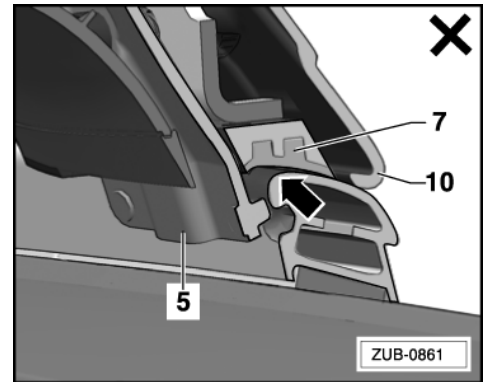

4.2 Installing add-on components

- Secure the add-on components in accordance with the relevant assembly instructions.



- To install the add-on components, remove the profile cap -17- from the profile tube -2- -arrow A-.
- Insert the add-on components in the T groove -arrow B-.
- Slide the profile cap -17- back on -arrow C-.

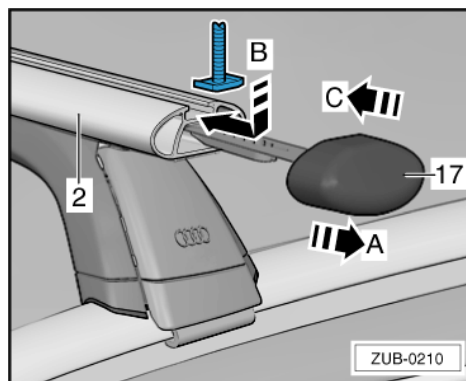

When the add-on components are not in use, seal the T groove with the profile cover -1-

- Adjust the profile cover -1- to the length of the profile tube -2- with the profile caps -17- closed.
- Position the profile cover -1- on the profile tube and press it into the T groove -arrow-.

Note

- ◆ *When driving with a roof load, ensure that the German Road Traffic Regulations (StVZO) or any country-specific regulations are observed.*
- ◆ *For reasons of convenience, it is common for the roof bars for roof rail with/without add-on parts to remain on the vehicle, even if they are not in use. As a result of the increased wind resistance, your vehicle will consume more fuel and will produce additional noise.*
- ◆ *We therefore recommend that you remove the roof bars for roof rail after use.*
- ◆ *Increased wind noise can result from driving with the roof bars for the roof rail.*

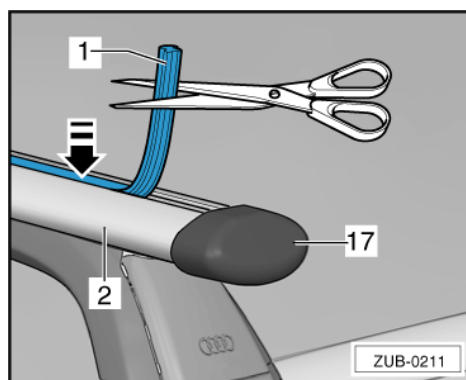

4.3 Removing the roof bars for roof rail

Note

The roof bars for roof rail must be removed by two people.

- Remove the load and the add-on components.
- Open the cover flap -12-.
- Loosen the left and right-hand tensioning bolts -13- alternately.
- Unscrew the tensioning bolts -13- alternately far enough for a certain amount of resistance to be detected.

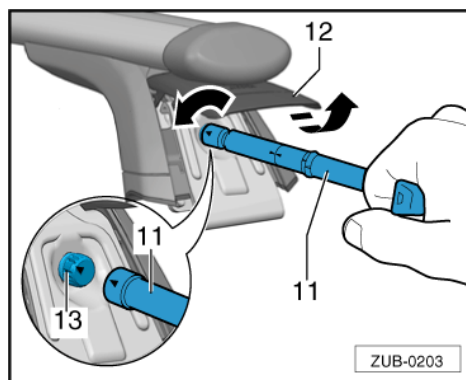



- Pushing the left and right tensioning bolts -13- to the vehicle centre -arrow A- will loosen the pin link -5- from the holes in the roof rail -arrow B-.
- Unhook the claw fasteners -10- on both sides -arrow C- and carefully remove the roof bars for roof rail.
- Screw in the tensioning bolts -13- by approx. 12 rotations and close the cover flap -12-.

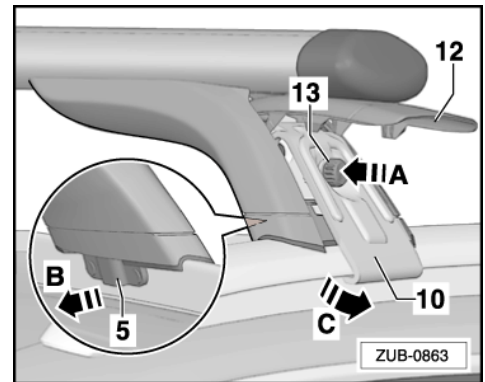

UK/US

4.4 General notes

Technical data

Weight of roof bars for roof rail: approx. 5 kg (11 lbs.)

Roof load/load

To determine the roof load:

- | |
|---|
| The weight of the roof bars for roof rail |
| + The weight of body part |
| + The weight of the load |
| = Roof load |

⚠ WARNING

Never exceed

- ◆ **the maximum permissible roof load (100 kg/220 lbs.)**
- ◆ **the gross axle weight rating**
- ◆ **the gross vehicle weight rating**

of your vehicle ⇒ Vehicle operating instructions.

Maintenance instructions:

The roof bars for roof rail should always be cleaned and kept in good order. It is particularly important to remove any dirt and salt in the winter.

4.5 Adjusting the width of the roof bars for roof rail

Instructions for the qualified workshop if the position of the support bracket for the relevant vehicle is not set correctly.

- Place the roof bars for roof rail on the vehicle ⇒ [Page 7](#) and gently tighten just the left-hand side.



- Use a 5-mm hexagon socket wrench to unscrew the hexagon bolts on the right-hand support bracket far enough that the support bracket can be moved. The roof bar for roof rail remains on the vehicle roof during this process.

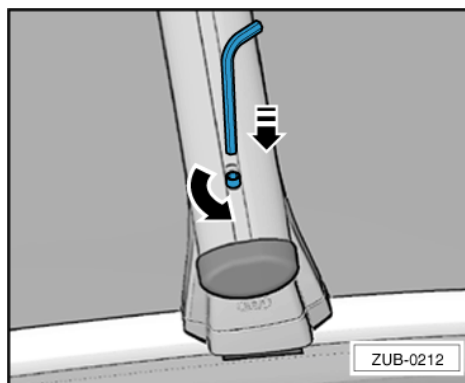

- Adjust the roof bars for roof rail -arrows A- so that the rubber supports for the right-hand lower support bracket -7- sit flush with the roof rail -arrows B-.

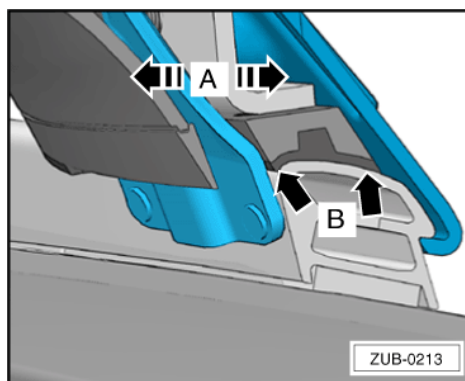

The roof bars for roof rail are in the correct position if:

- ◆ The rubber supports for the lower support bracket -7- sit flush against the roof rail -arrows-
- ◆ The pins in the pin links -5- engage in the holes -X- in the roof rail
- ◆ The claw fastener -10- is hooked under the roof rail

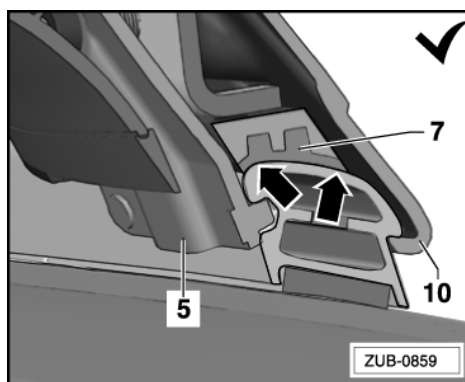

- Tighten the hexagon socket bolt to 10 Nm.
- If necessary, repeat this process on the other roof bars for roof rail.

⚠ WARNING

Check that all hexagon bolts have been tightened (to 10 Nm). If this guideline is not observed, this can result in the roof bars for roof rail coming loose or falling off — risk of accident!

